

OPERATING AND MAINTENANCE
INSTRUCTIONS
for

TYPE 1217-A UNIT PULSER

DO NOT
INSTRUMENT
CALIBRATION
USE ONLY

LOAN OUT



NOTED

INST CALIB
GENERAL RADIO COMPANY

CAMBRIDGE 39, MASSACHUSETTS, U. S. A.

**OPERATING AND MAINTENANCE
INSTRUCTIONS
for
TYPE 1217-A UNIT PULSER**

Form 852-D
December, 1958

GENERAL RADIO COMPANY

275 MASSACHUSETTS AVENUE, CAMBRIDGE 39, MASSACHUSETTS

PHILADELPHIA: 1150 York Road
Abington, Pennsylvania
WASHINGTON: 8055 13th Street
Silver Spring, Maryland

NEW YORK: Broad Avenue at Linden
Ridgefield, New Jersey
CHICAGO: 6605 West North Avenue
Oak Park, Illinois
CANADA: 99 Floral Parkway
Toronto 15, Ontario

LOS ANGELES: 1000 North Seward Street
Los Angeles 38, California
SAN FRANCISCO: 1182 Los Altos Avenue
Los Altos, California

REPAIR SERVICES

NEW YORK
General Radio Company
Service Department
Broad Avenue at Linden
Ridgefield, New Jersey

EAST COAST
General Radio Company
Service Department
22 Baker Avenue
West Concord, Massachusetts

MIDWEST
General Radio Company
Service Department
6605 West North Avenue
Oak Park, Illinois

WEST COAST
Western Instrument Company
826 North Victory Boulevard
Burbank, California

CANADA
Bayly Engineering, Ltd.
First Street
Ajax, Ontario



Figure 1. Panel view of Type 1217-A Unit Pulser.

SPECIFICATIONS

Pulse Repetition Rates: 30 c, 60 c, both synchronized to power line; 100 c to 100 kc in 1-2-5 steps, $\pm 15\%$ or 20 c whichever is greater; 15 c to 100 kc continuous with external source.

Pulse Duration: Continuous coverage in four ranges 0.2 to 60,000 μ sec. Accuracy $\pm 15\%$ or 0.2 μ sec, whichever is greater.

Pulse Shape: Rise time 0.05 μ sec, Fall time 0.15 μ sec with output terminals shunted by 15 μ f and 1 M Ω . The overshoot may be set to be less than 5% of one-half the maximum amplitude, and the top of the pulse is flat to within 5% of maximum amplitude of all durations.

Minimum External Drive Voltage: 26 volts or less, rms, for continuous locking from 15 c to 85 kc; 40 v, up to 100 kc; a 10-volt pulse will lock continuously from 0 to 25 kc. TYPE 121C-B Unit R-C Oscillator is recommended.

Output Impedance: 200 ohms for positive pulses, 1500 ohms for negative pulses.

Open Circuit Output Voltages: 20 volts for pulses of either polarity; negative pulse of 50 volts when positive output terminal is grounded.

Stability: No time jitter is visible where a full period is displayed on an oscilloscope.

Tube Complement: 6AK5, 6AN5, 6AL5, 6485 and two 12AT7.

Accessories Supplied: One multipoint connector, 10:1 200 Ω attenuator.

Power Supply: 300 volts, 55ma; 6.3 volts, 2a. TYPE 1203-A Unit Power Supply is recommended.

Dimensions: (Width) 10 $\frac{5}{8}$ x (height) 5 $\frac{3}{4}$ x (depth) 6 $\frac{1}{4}$ inches over-all, not including power-line connector cord.

Net Weight: 5 $\frac{3}{4}$ pounds.

THIS APPARATUS USES INVENTIONS OF UNITED STATES PATENTS LICENSED BY RADIO CORPORATION OF AMERICA. PATENT NUMBERS SUPPLIED UPON REQUEST. NOT LICENSED FOR DOMESTIC, FIXED-STATION, PUBLIC SERVICE COMMUNICATION FOR HIRE OR TOLL.

Operating Instructions

for

TYPE 1217-A UNIT PULSER

SECTION 1.0 DESCRIPTION

1.1 INTRODUCTION - GENERAL DESCRIPTION

The Type 1217-A Unit Pulser is a general-purpose pulse generator. It produces a pulse with a wide range of time durations. The repetition period of this pulse is determined either by the oscillator contained within the instrument or by an external frequency source. The output pulse is available in either polarity, and a negative synchronizing pulse preceding the main pulse by approximately 0.1 μ sec is provided to lock the sweep of an oscilloscope.

1.2 BASIC CIRCUITS

Four basic circuits are used in the Type 1217-A Unit Pulser. With reference to Figure 2, these are:

1. A blocking oscillator which can be operated as a free-running relaxation oscillator at any one of 12 selected frequencies, or as a driven (synchronized) oscillator over the frequency range to 100 kc.
2. A monostable multivibrator producing the pulse of variable duration.
3. A limiter-type amplitude control circuit permitting adjustment of the output pulse amplitude while maintaining good pulse shape and a minimum of amplitude variation due to changes in pulse duration or period.
4. An output cathode follower which can be converted (by moving a binding post link) to an amplifier producing a negative pulse, or a phase splitter.

1.3 CONTROLS AND CONNECTIONS

1.31 Controls: There are four main controls. With reference to Figure 1, the pulse-repetition-frequency selector is located on the right side

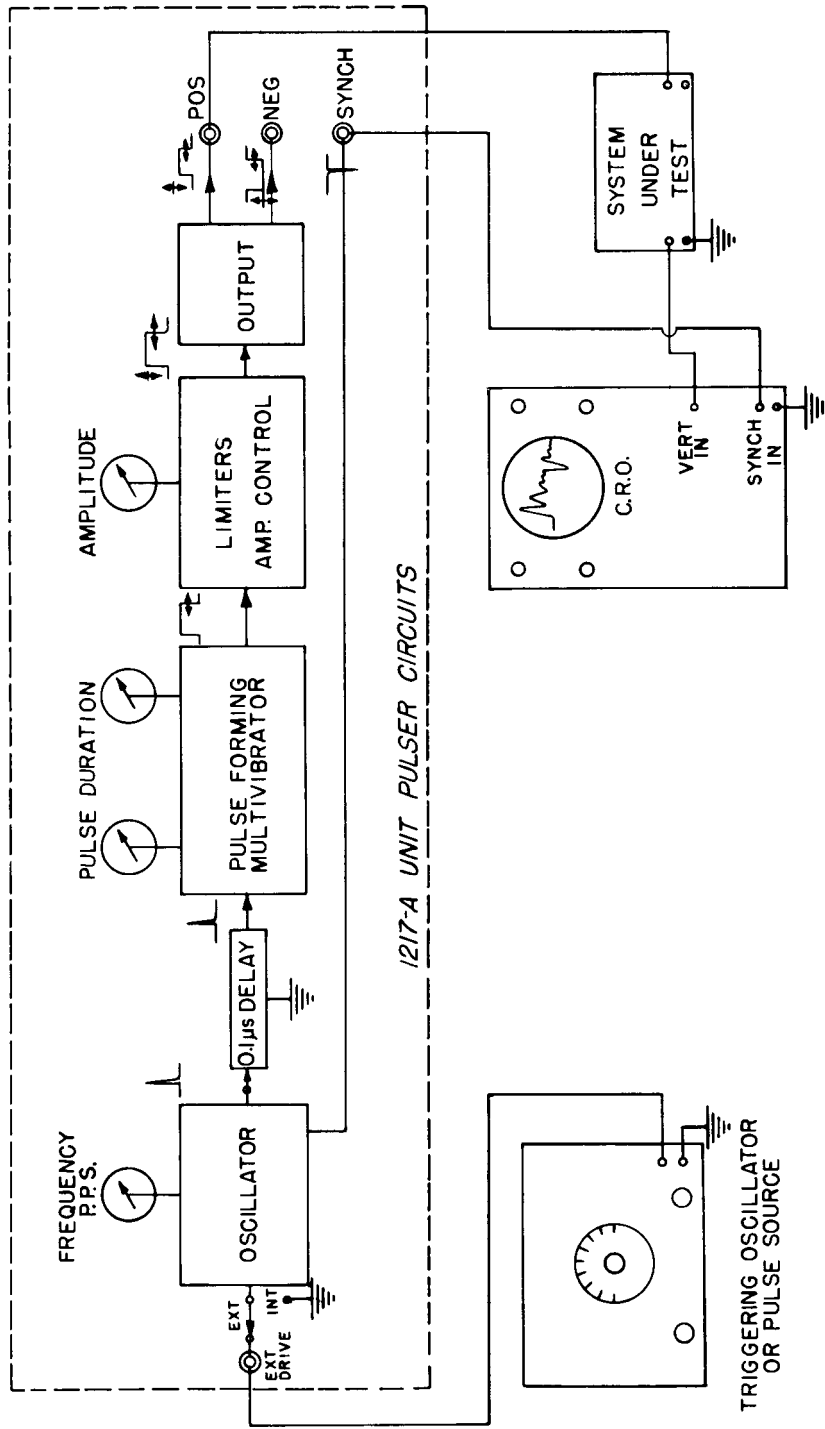

Figure 2. Block diagram of the Type 1217-A Unit Pulser showing the functional arrangement of internal circuits, and connections to external equipment.

TYPE 1217-A UNIT PULSER

of the panel and is marked PULSES PER SECOND. This control will set the free-running frequency of the blocking oscillator. (See Section 2.2 if oscillator is to be triggered by an external source.) Next, reading from right to left, is the AMPLITUDE control, which will vary the amplitude of either the positive or negative pulse from 1 to 20 or more volts. The two controls on the left side vary pulse duration. The basic PULSE DURATION range is 0.6 to 6 μ sec by a continuous adjustment. The five-position ($X1$, $X10$, $X10^2$, $X10^3$, $X10^4$) MULTIPLIER operates on the MICROSECONDS dial reading to provide a continuous range to 60,000 μ sec (a square wave at approximately 8 cps). The basic range for the PULSE DURATION control is modified by a special scale for the $X1$ multiplier setting so that pulse durations as brief as 0.2 μ sec may be obtained. For the $X1$ RANGE, the outside scale of the DURATION dial is used; for all other ranges, the inside scale applies. A screwdriver adjustment for the shape of the leading edge of the pulse is provided by the OVERSHOOT control located top-center of the front panel. Adjustment of this capacitor with a non-metallic screwdriver will permit the user to optimize the shape of the pulse for his particular application.

1.32 External Connections: The use of the binding posts for external connections will be made clear by reference to Figure 2. Reading from left to right terminal pairs provide the following connections to external circuits:

1. EXTERNAL DRIVE permits the Type 1217-A to be driven by a source of either sine-wave or pulse voltage. (A switch is provided next to this jack to disable the internal free-running oscillator when an external driving source is used.)
2. SYNCHRONIZING permits the Type 1217-A to drive a synchroscope or other device which responds to a negative pulse.
3. The NEGATIVE main pulse output.
4. The POSITIVE main pulse output.

1.33 Power Supply: Any power supply capable of providing 300 v dc at 55 ma and 6.3 v ac at 3 a may be used provided that neither the positive nor negative plate supply terminals are connected to chassis ground. A General Radio Type 1203-A or 1204-B Unit Power Supply is recommended. When very low noise is required in the negative pulse, it may be desirable to use a well-filtered, regulated power supply.

1.34 Auxiliary Apparatus: Since the pulser is generally used for tests and experiments in the time domain, the principle item of auxiliary apparatus is an oscilloscope. The required characteristics of the oscilloscope, in particular the frequency response, depend upon the range of pulse durations to be displayed. See Section 2.14 for a discussion of this subject.

When the pulse repetition frequency is to be controlled externally, an oscillator or other suitable source is required. The General Radio

GENERAL RADIO COMPANY

Type 1302-A Oscillator is recommended. For synchronization over the entire range to 100 kc, 25 volts behind a maximum of 500 ohms is required; up to 25 kc, 10 volts; and up to 5 kc, 5 volts.

1.4 ACCESSORIES SUPPLIED

1.41 Power Plug: A four-prong plug is provided to couple the Unit Pulser to an external power supply other than the Type 1203-A. Power requirements are 6.3 v ac at 3 a and 300 v dc at 55 ma.

1.42 10:1 200 Ω Attenuator Type 1217-P1: A 10:1 attenuator is provided to reduce the output pulse amplitude by 20 db for low-level testing where good pulse shape and freedom from noise at low pulse amplitudes are desirable. An external resistor can be connected at the output terminals of this attenuator to match cables or low-impedance transmission lines.

SECTION 2.0 OPERATION

2.1 GENERAL (Internal Oscillator)

2.11 Power Supply: See Section 1.33.

2.12 Connections and Control Settings: The following operations describe a typical set-up procedure for an oscilloscope and the pulser.

1. Connect an oscilloscope to the pulser and set it to display a 1000-microsecond square wave:

a. Connect SYNCHRONIZING post on Type 1217-A to synchronizing signal input of the oscilloscope.

b. Set the synchronizing controls of the oscilloscope for a negative synchronizing signal polarity.

c. Connect the positive pulse output post on the Type 1217-A to the VERTICAL input of the oscilloscope.

2. Now set the controls of the pulser to produce a 1-kc square wave as follows:

a. MICROSECONDS: to 5 on inside scale.

b. MULTIPLIER: to X100 position.

c. AMPLITUDE: to maximum clockwise position.

d. PULSES PER SECOND: to 1 k.

e. TRIGGER SELECTOR: to the INTERNAL position.

3. The oscilloscope and the power supply for the pulser can now be turned on.

4. After warm-up, the trace and amplitude controls of the oscilloscope can be adjusted to display the 1-kc square wave, and the user can familiarize himself with the operation of the pulse duration controls by experiment.

TYPE 1217-A UNIT PULSER

2.13 Operating Precautions: Since there are no restrictions on the duty-ratio of the Type 1217-A (duty-ratio is the ratio of pulse-on time to total time for a period), it is always possible to set the PULSE DURATION controls to produce a pulse of greater duration than the period. The instrument will not be damaged by operation in this fashion, but the user may be confused by the resulting display. UNSTABLE OPERATION WILL RESULT WITH PULSE DURATIONS BETWEEN 0.6 and 1.0 TIMES THE PERIOD. The table of Figure 3 provides a reference to the twelve basic periods and the probable maximum stable pulse duration.

<u>Pulses per Second</u>	<u>Period</u>	<u>Maximum Stable Pulse Duration</u>
30	33,333 microseconds	17,000 microseconds
60	16,667 "	10,000 "
100	10,000 "	6,000 "
200	5,000 "	3,000 "
500	2,000 "	1,200 "
1 k	1,000 "	600 "
2 "	500 "	300 "
5 "	200 "	120 "
10 "	100 "	60 "
20 "	50 "	30 "
50 "	20 "	12 "
100 "	10 "	6 "

Figure 3. Periods and maximum pulse durations as a function of repetition frequency.

Figure 3 is simply a tabulation for easy reference of the simple equation relating period and frequency:

$$\text{Period (in microseconds)} = \frac{10^6}{\text{Pulses per second}}$$

If the pulser is operated from an external source of synchronizing voltage, the maximum stable period can either be determined by experiment (approaching and exceeding a square wave at the given frequency) or it can be calculated.

If the pulse duration is set to exceed the period, the monostable multivibrator used to produce the pulse will "count-down". For example, if the pulse duration is set between 1000 and 1500 microseconds with a 1-kc repetition rate, a pulse of the proper duration will be produced but only every other triggering pulse from the oscillator will be accepted and the repetition rate for the output pulse will be 500 cps, etc. Naturally, as the counting-down process is continued so that the pulse duration is several times the period, the time region over which a stable pulse is produced will be lessened, and some disturbance in the output pulse may be seen each time the triggering pulse is produced by the oscillator.

GENERAL RADIO COMPANY

2.14 Special Considerations for Pulses of Very Long or Very Short Durations: When pulses of very long or very brief duration are to be produced and observed, the user must give special attention to the apparatus set-up and interconnections. Bandwidth considerations are fundamental, and oscilloscopes suitable to provide the desired frequency response must be chosen as indicators.

1. Long Pulse Durations:

a. **OSCILLOSCOPE:** An oscilloscope having a frequency response to dc is desirable for the observation of pulses of long duration. Most oscilloscopes not having d-c amplifiers will have their low-frequency cutoff around 5-10 cps and will show "ramp-off" effects with pulse durations in excess of 10,000 microseconds. In general, any indicator will have adequate high-frequency response for the long-duration pulses, since the "flats" are usually of more interest than the rapid rise and fall of voltage.

b. **PULSER:** The pulser has a direct-coupled output system for positive pulses and will not show "ramp-off" at any duration. (Ramp-off is slope on the flat "top" and "bottom".) The output coupling system for the negative pulses consists of two 0.47- μ f capacitors in series with two 5.6-megohm resistors so the output coupling time-constant for negative pulses is roughly 2.5 seconds which is adequate in the 60,000-microsecond pulse on open circuit. If, however, the negative pulse terminals are coupled into a circuit where the input resistor is 1 megohm, the time constant would be reduced to approximately 0.25 second; and a ramp-off of approximately 25% can be expected with a 60,000 μ sec pulse.

The user will note that the ground (lower) binding post for the negative pulses is insulated from ground. This has been done to bring about a reduction in power supply hum in the negative pulse. When a negative pulse is used, the ground lead between the pulser and external systems should be connected to this insulated binding post if a minimum of power supply ripple is to be obtained in the pulse. If, on the other hand, any other ground post on the pulser is used, the negative pulse will contain hum equal to that on the B+ of the power supply feeding the pulser. (This quantity is 250 mv rms for the General Radio Type 1203-A Unit Power Supply.)

2. Short-Pulse Durations: The faithful reproduction of pulses of short duration, or of the rapidly changing voltage of the leading or trailing edges of such pulses, requires amplifier and indicator systems having wide bandwidth. If, for example, one attempts to display a pulse with a rise-time of 0.05 microsecond on an oscilloscope with an amplifier system having a rise-time of 0.05 microsecond, the indicated rise-time will be $\sqrt{2} \times 0.05 \mu\text{s} = 0.07 \mu\text{s}$. For a system having n individual components of specified rise-time, the equation for over-all rise-time is,¹

1. Valley, G.E., and Wallman, Henry, Vacuum Tube Amplifiers, Radiation Laboratory Series, Vol. 18, McGraw-Hill, 1948, p.77.

TYPE 1217-A UNIT PULSER

$$\text{Eq. 1 } T_R = \sqrt{T_1^2 + T_2^2 + \dots T_n^2}$$

The rise-time of an amplifier system, T_R , is related to the 3-db bandwidth, B , by Equation 2,² where the factor of 0.35 should be used if the overshoot is less than 5%.

$$\text{Eq. 2 } T_R = \frac{0.35 \text{ to } 0.45}{B}$$

When using brief pulses, it is necessary to use care in wiring components together. Short, direct, wires should be used for both signal and ground wires if open wiring is used, and care should be taken to terminate coaxial cables properly. A frequent sign of improperly connected ground or inductance loop in wiring is the presence of high-frequency ringing (damped-oscillation) on the pulse transitions.

2.15 Shape (overshoot) Adjustments: There are possible applications for the pulser in which a minimum of rise-time (even with some overshoot) is most desirable. There are also other applications in which it is most desirable that the pulse waveform be completely free from any overshoot, even at the expense of increased rise-time. To optimize the applicability of the instrument, a screwdriver adjustment affecting the leading edge of the pulse is provided. With this control, the overshoot may be set with a non-metallic screwdriver to suit individual desires. With the maximum overshoot of 5 to 10%, a properly operating instrument will deliver pulses with rise-times on the order of 0.035 to 0.04 microsecond.

2.2 OPERATION FROM AN EXTERNAL DRIVING SOURCE

Setting the trigger switch to EXTERNAL will disable the internal oscillator (in all PPS switch positions but 30 c, 60 c and 100 kc). Application of a triggering voltage source of the EXTERNAL DRIVE terminal pair will then control the pulse recurrence rate.

The Type 1217-A Unit Pulser can be driven by a source of either sine waves or pulses. When sine waves are used to drive the instrument, the output frequency is "pulled" by the driving source. Figure 5 shows the synchronizing characteristics of a typical instrument for different voltages from the trigger source and different repetition-rate switch settings, as a function of driving frequency. For example, with a PULSE PER SECOND switch setting of 1 k, with a driving voltage source of 15 volts rms, the pulse-recurrence frequency can be pulled from 700 to 1500 cps, while for 5 volts, the range is 230 cps to 800 cps.

2. Valley, G.E., and Wallman, Henry, Vacuum Tube Amplifiers, Radiation Laboratory Series, Vol. 18, McGraw-Hill, 1948, p.80.

GENERAL RADIO COMPANY

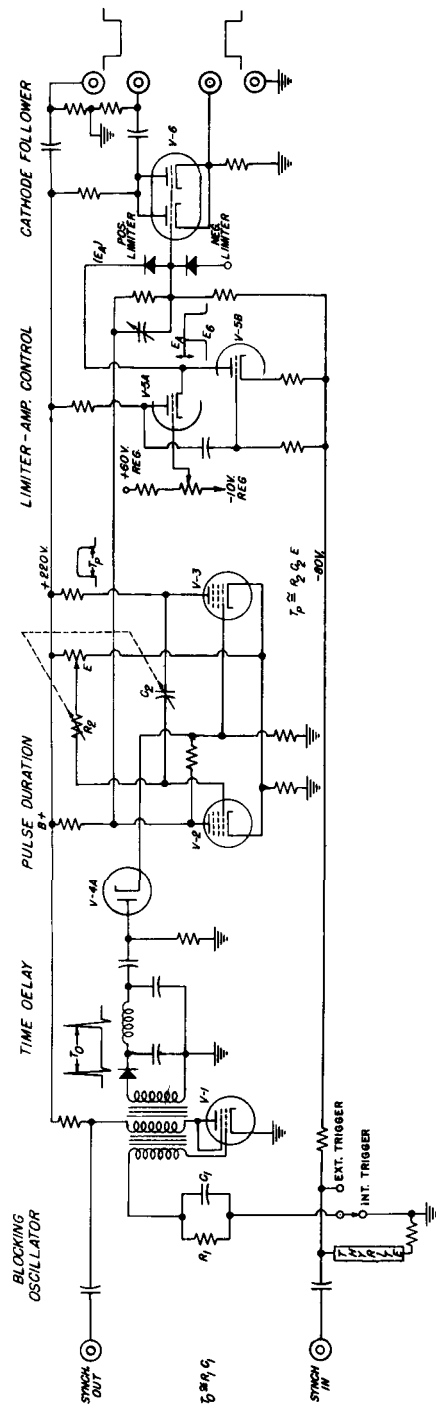

Figure 4. Elementary schematic diagram.

TYPE 1217-A UNIT PULSER

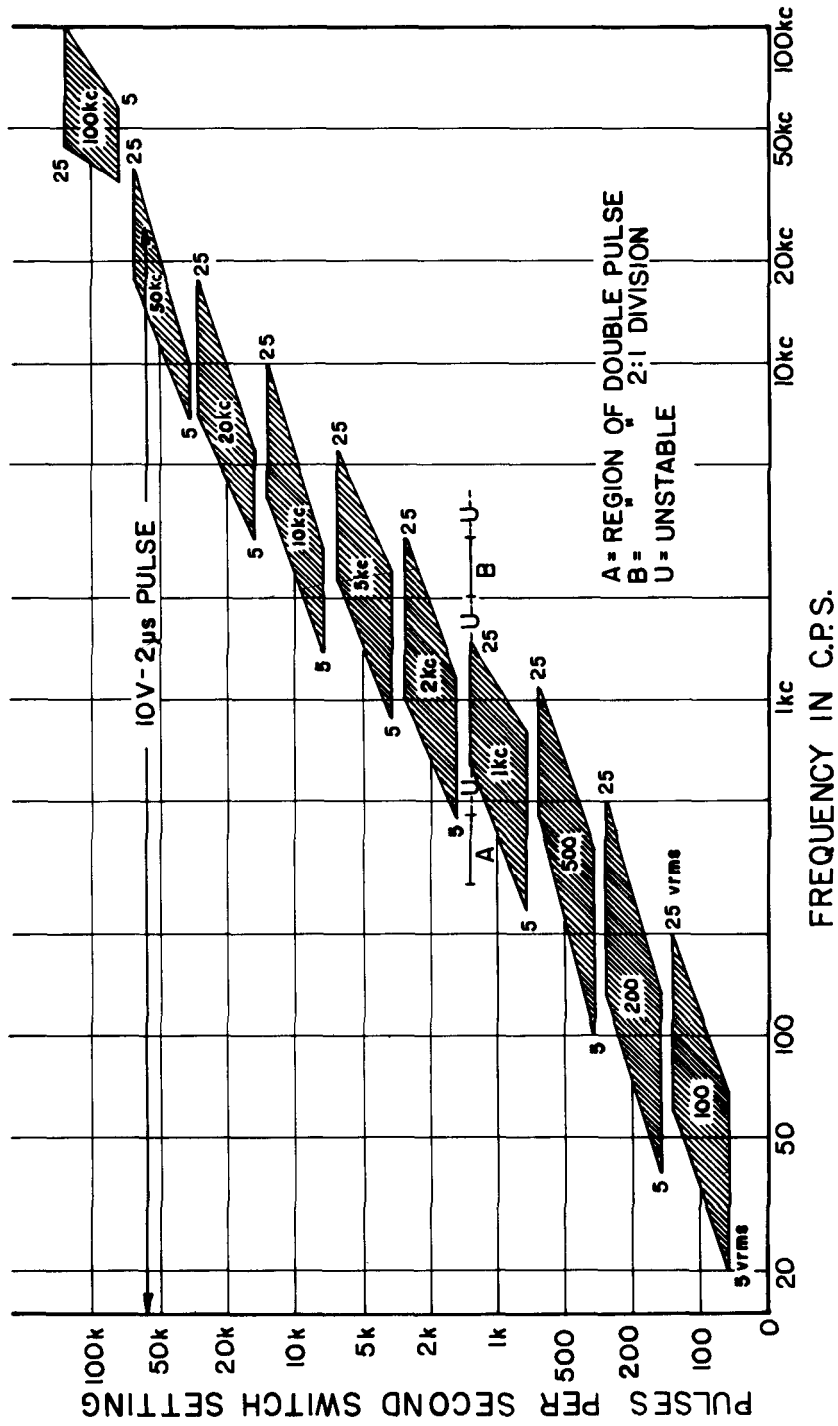

Figure 5. Synchronizing characteristics of a typical Type 1217-A Unit Pulser.

GENERAL RADIO COMPANY

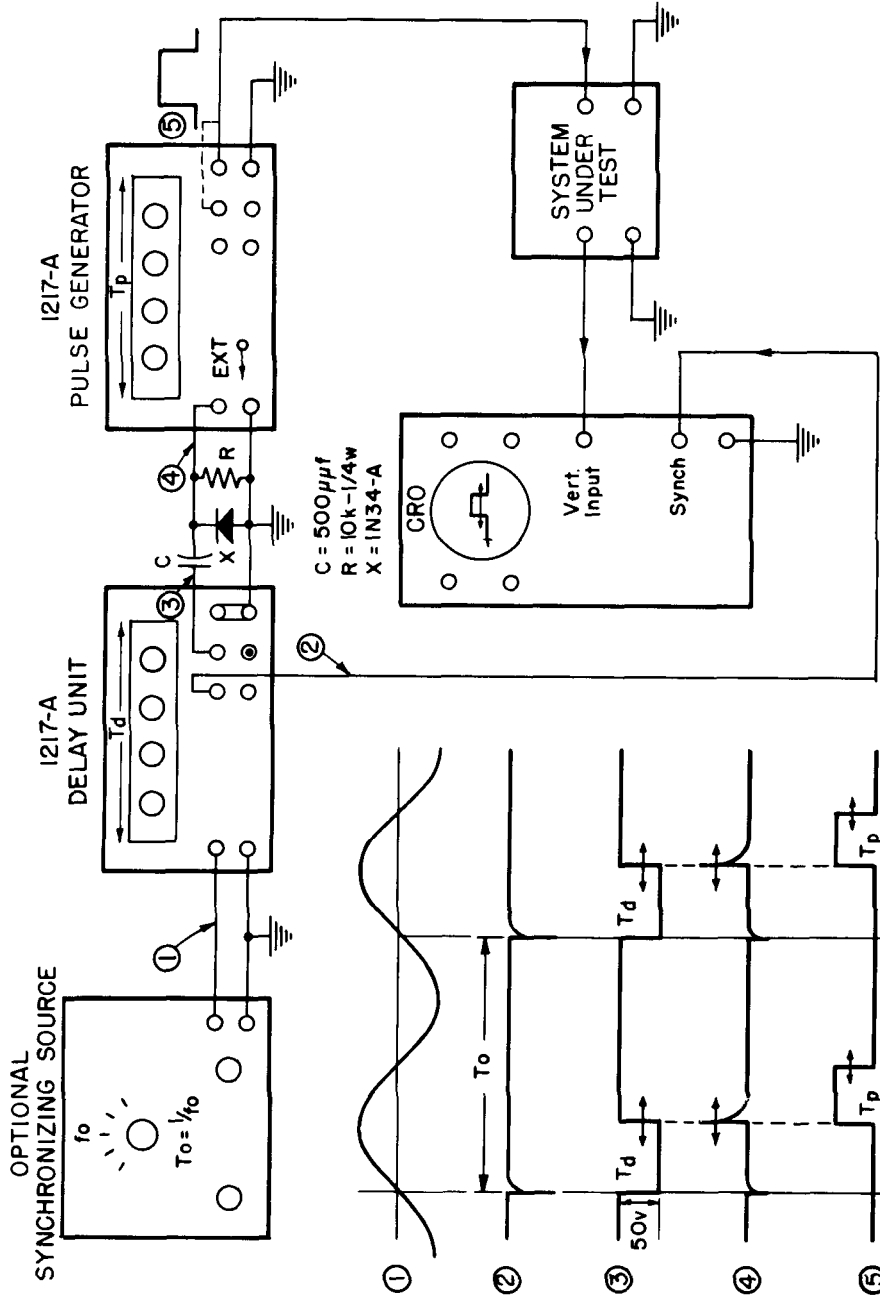

Figure 6. Two Type 1217-A Unit Pulsers connected to provide pulses with adjustable time delay.

TYPE 1217-A UNIT PULSER

For values of voltage or driving frequency greater than, or less than, those within the shaded regions on the plot, one of three effects will be observed:

1. Jittery or unstable locking between the triggering waveform and output pulse, or
2. Frequency division, wherein the pulse is produced at a lower frequency than that of the locking voltage, or
3. Double- or multiple-pulsing (two or more pulses per trigger cycle).

The first condition will always prevail on the boundaries of loci of Figure 5. The second condition will arise when the locking frequency is in the region of twice, three times, etc., the 1:1 synchronizing locus for a given synchronizing voltage. The third condition will arise when the synchronizing frequency is less than that required for 1:1 division. Regions of double pulsing and 2:1 frequency division are shown for an input of 25 volts with the 1 kc switch setting in Figure 5, as an example. Experimenting will familiarize the user with these effects.

With the trigger selector switch set in the EXTERNAL position on all PPS switch settings other than 30 c, 60 c, and 100 kc, a bias is provided to disable the oscillator tube completely. A brief pulse capable of driving the oscillator of the pulser into conduction, and then no longer interfering with its operation will provide a very wide range of synchronization. As an example of pulse drive, Figure 5 shows the locking range (0+ to 25 kc) for a pulse of 10 volts amplitude and 2 microseconds duration with the PPS switch set to 50 kc.

2.3 USE OF THE PULSER AS A DELAY GENERATOR; OPERATION IN TANDEM

The "trailing edge" of the adjustable duration pulse from a Unit Pulser can be formed, by differentiation, into a delayed trigger pulse. This pulse can be used to trigger a second Unit Pulser set for external drive. A positive pulse is needed to trigger the second pulser. The negative pulse from the first pulser should be used to drive the differentiator. A complete sketch of this set-up is shown in Figure 6. The PULSE DURATION controls on the first pulser determine the time delay between the synchronizing pulse and the output trigger pulse from the differentiator. The repetition rate for the system is set by the first pulser, which can operate on its own oscillator, or with an external driving source.

2.4 SPECIAL OPERATIONS

2.41 Frequency Adjustments With An Unsynchronized Oscillator: It is possible, by changing a component, to obtain an oscillator frequency different from that shown on the front panel. The blocking oscillator frequency is determined by a parallel combination of resistance and ca-

GENERAL RADIO COMPANY

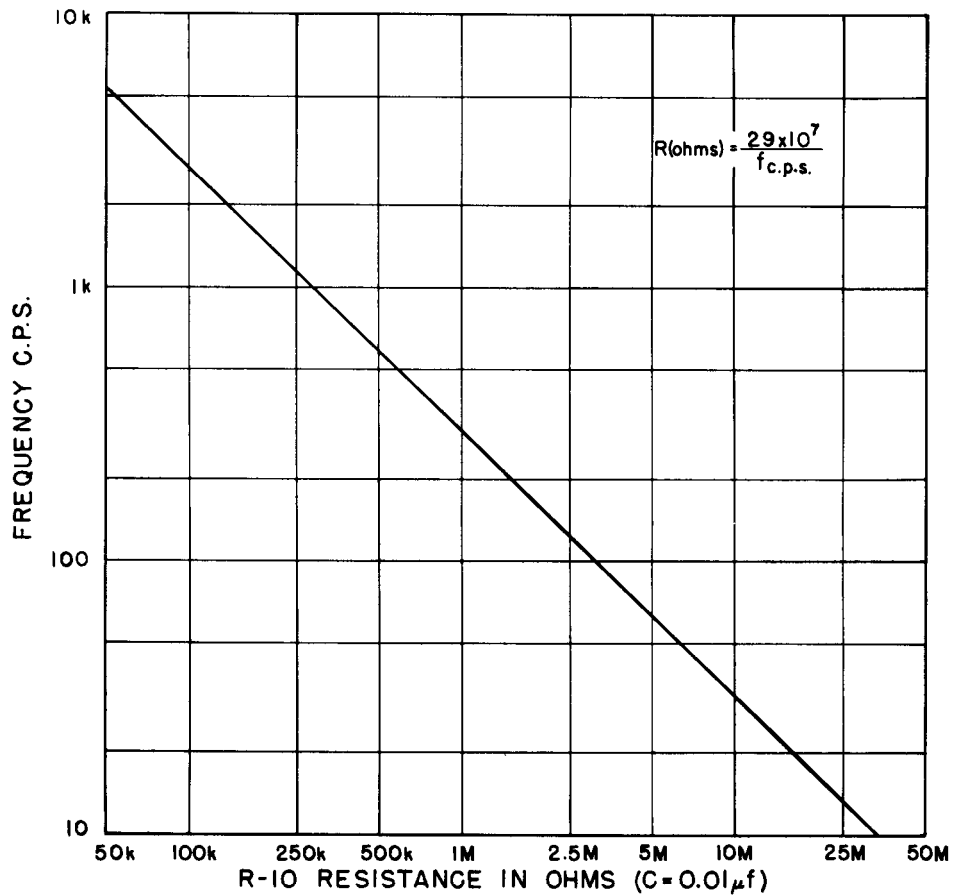

Figure 7. Pulse repetition frequency as a function of resistance R-10.

capitance. At the 100-cycle position of the PULSES PER SECOND switch, for example, major frequency-determining elements are R-10 and C-2: R-10 equals 2.7 megohms for a frequency of 100 cycles, 5.4 megohms for 50 cps, 10 megohms for 25 cps, etc. The substitution of a 100-megohm resistor for R-10, for example, will provide an output frequency of 3 cps. Figure 7 gives a plot of frequency as a function of R-10 with the PULSES PER SECOND switch set in the 100-cycle position. Naturally, if it is not desired to have such large values of R-10, C-2 may be increased. It is not recommended that the free-running frequency be increased indefinitely by decreasing the value of R-10 because the average grid current of V-1 will become excessive. With no decrease in C-2, the pulse-recurrence frequency should be limited to values below 10 kc.

2.42 Line-Frequency Locking: The 30-c and 60-c positions of the PULSES PER SECOND switch are locked to the power frequency by an internal connection to the heater voltage. The locking range is set by

TYPE 1217-A UNIT PULSER

the potentiometer R-58 which varies bias on V-1. It is possible to lock to multiples and submultiples of line frequency by varying the setting of R-58 (for wide ranges, R-12 may also be varied). For example, the 30-cycle PULSES PER SECOND switch setting can be caused to provide frequencies of 15, 20, 30 cps, etc., by this procedure. With 50-cycle line frequencies, this operation will produce 12-1/2, 16.66, 25 cps, etc.

2.43 Provisions For Operating On Line Frequencies Other Than 60 CPS: R-11 and R-12, along with C-3 and C-4 of Figure 10, are the basic frequency-determining elements for the normal 30 c and 60 c pulse recurrence frequency switch settings. Since period is directly proportional to the RC product, changing R-11 or R-12 will permit locking at other line frequencies. The locking range provided by R-58 (Section 2.42) is great enough so that no component change will be needed for 50-cycle line frequencies with most oscillator tubes.

2.44 Using The Output Tube As A Pulse Amplifier: The Type 1217-A Unit Pulser is shipped from the factory connected for positive pulse output with a shorting bar across the negative pulse terminals. If this shorting bar is removed, there will be very little change in the output voltage for positive pulses on open circuit, and a decrease of about 20% in the maximum positive output pulse into 50 ohms. If the shorting bar is moved from the negative to the positive output pair, the output tube is converted into a pulse amplifier capable of delivering a negative pulse of 60 volts amplitude on open circuit. ~~The pulse will attain maximum amplitude~~ BEFORE THE AMPLITUDE CONTROL REACHES ITS MAXIMUM SETTING. After that point the output stage will overload and a small spike will form on the leading edge. It is not recommended that the output control be advanced beyond the point where maximum amplitude is obtained or left beyond this point for any extended period of time because damage to the output tube may occur.

SECTION 3.0 CIRCUIT DESCRIPTION

3.1 INTRODUCTION

Section 1.0 describes briefly the four main circuit groups which make up the pulser, and Figure 2 shows these groups in block form. This section will discuss these circuits in sufficient detail to permit the user to obtain a maximum application of them to his specific measurement or research problem. This section together with Section 4.0 will make it possible to locate and repair any difficulties or failures in the operation of the instrument.

GENERAL RADIO COMPANY

3.2 OSCILLATOR

The blocking oscillator (Figure 10) consists of the oscillator tube, V-1, a pulse transformer, and a group of RC circuits which determine the oscillator period and inject synchronizing signals.³⁻⁴ When the oscillator tube conducts, the plate current in the pulse-transformer primary induces a voltage in the grid winding. This voltage tends to drive the grid positive with increasing plate current. The positive feedback from plate to grid drives the grid positive with respect to ground, and the large burst of grid current charges grid capacitor C. When the rate of change of plate current in the transformer primary decreases, the positive voltage induced on the grid of V-1 decreases, and the charged grid capacitor quickly drives the tube into cutoff. The duration of this plate-current pulse depends upon the characteristics of the tube and transformer and upon the value of the grid capacitor. This time varies from about 2 microseconds at 30 cps and 60 cps to about 0.25 microseconds for the 50- and 100-k positions of the PULSES PER SECOND switch. The switch selects an RC value appropriate to the desired repetition rate. Since the time of the plate current pulse is so brief, most of the time of the period is produced by the discharge of the grid capacitor through the resistor selected by the PULSES PER SECOND switch. The initial value of voltage determined by the amplitude of the plate current pulse and the value of voltage at which the tube will again begin to conduct determines the period. The basic time equation is,

$$\text{Eq. 3 } T_{\text{period}} = T_{\text{pulse}} + RC \log_{\epsilon} \frac{E_m}{E_{CO}}$$

where E_m and E_{CO} are the values of initial and cutoff voltage, respectively.

The RC timing networks for the ten unsynchronized frequencies are connected to ground through the TRIGGER SELECTOR switch (S-2) when it is set in the INTERNAL position. When this switch is set to EXTERNAL, a bias of approximately 35 volts is applied to the ground end of the timing networks. This voltage is developed by a voltage divider consisting of R-16, R-17, and a Thyrite resistor. Any synchronizing signal applied to the EXTERNAL DRIVE terminal (J-3) is applied through capacitor C-6 to add to this bias voltage and to drive the oscillator tube into periodic conduction. With a sine wave as the synchronizing signal, there is only a limited range of locking depending upon the RC timing circuit, the amplitude of the synchronizing voltage, etc. (See Figure 5.) A pulse of voltage added to the fixed cutoff bias on V-1 will

3. Benjamin, R., "Blocking Oscillators", Proc. IEE, pt. III-A, 1947, p.10.

4. Moskowitz, S. and Racker, J., Pulse Techniques, Prentice-Hall, 1951, p.195.

TYPE 1217-A UNIT PULSER

cause conduction and serve to lock the oscillator over a very wide range of frequencies.

A fixed bias voltage, developed across R-58, and 6.3 volts at the line frequency from the heater supply are combined to synchronize the pulser at 30 and 60 cps (or other line frequencies). (R-58 is made adjustable so that the user of the instrument can readjust for most reliable locking when V-1 is replaced by a new 6AN5 tube having different characteristics from those of the original and to allow the oscillator to be locked to line frequencies other than 60 cps.)

The pulse of plate current in the blocking oscillator tube produces a negative pulse across R-19, which is coupled through C-22 to the SYNCHRONIZING output terminals J-1. This pulse (Figure 8) has a peak amplitude of about 20 volts and can be used to synchronize an oscilloscope or other apparatus. R-18 and C-5 provide a decoupling network to remove high-frequency components in the oscillator plate current from the B+ voltage.

The third winding on T-1 produces a positive pulse during the conduction of the blocking oscillator tube. This pulse is applied through a delay network and coupling diodes to the monostable circuit. The network L-1, C-15, and C-21 provides, with distributed capacitances, a relay of about 0.1 microsecond between the rising edge of voltage at the blocking oscillator transformer and the rise of the voltage at the monostable circuit. This delay will permit the synchronizing pulse generated by the blocking oscillator to start the sweep on a synchroscope before the output pulse is produced.

The trigger pulse generated by the oscillator is passed to the pulse-generating multivibrator through C-8. In earlier instruments, this capacitor is a fixed mica. In instruments of later production than Serial No. 175, this capacitor is made variable to permit adjustment of the trigger pulse to the pulse-generating circuits. Aging or replacement of the oscillator tube might require that the trigger coupling be increased by increasing the coupling capacitance. (See Sections 4.36 and 4.5.)

3.3 PULSE-GENERATING MONOSTABLE CIRCUIT

V-2 and V-3 of Figure 4, with their associated components, constitute a monostable multivibrator which initiates the output pulse after being triggered by the positive pulse from the blocking oscillator. The output pulse is timed by means of an adjustable voltage (the MICROSECONDS control) and adjustable RC elements (the MULTIPLIER control). The positive pulse to drive the output circuit is produced at the plate of V-1. Before the positive trigger pulse from the oscillator is received, the circuit is sitting in its stable condition with V-2 conducting and V-3 beyond plate current cutoff. (The grid of V-2 is returned to a sufficiently positive voltage on R-43 to produce a value of plate voltage low enough

GENERAL RADIO COMPANY

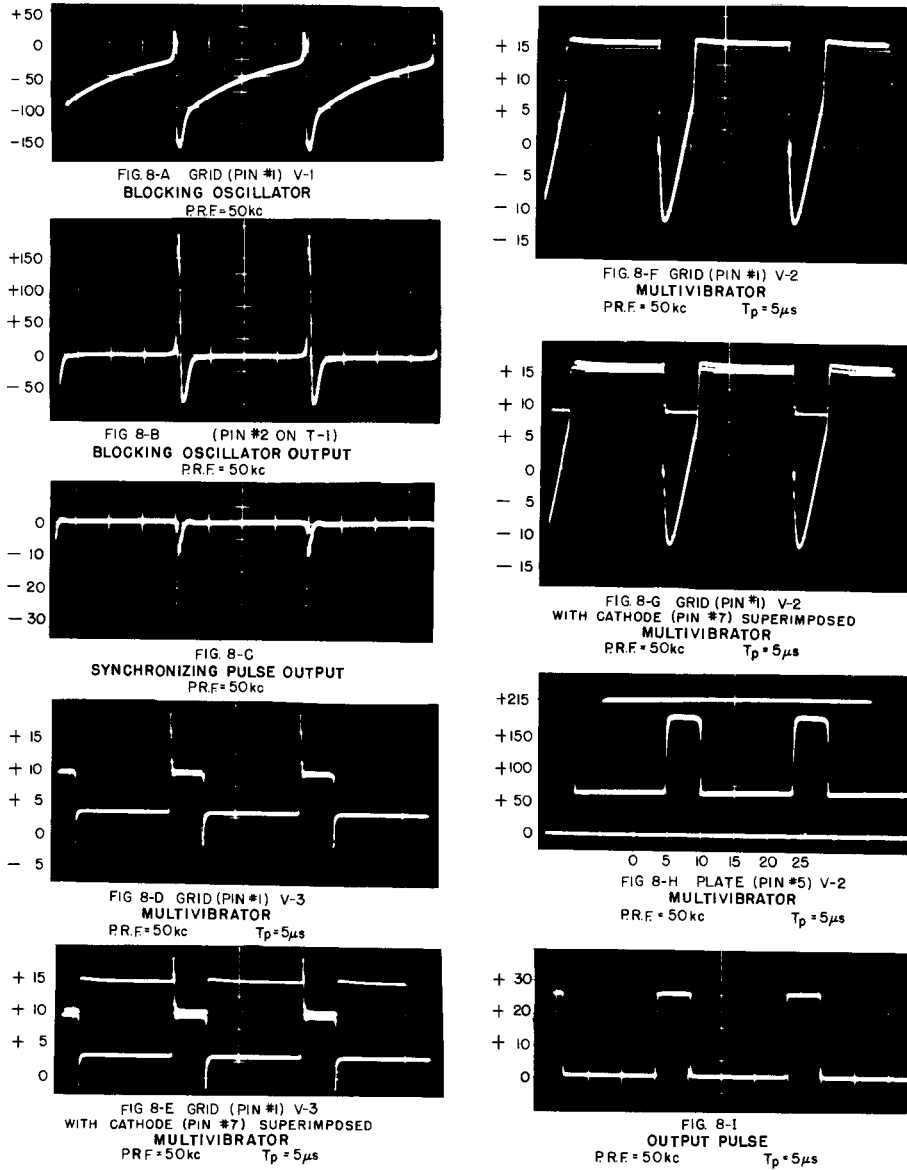

Figure 8. Waveform photographs taken at the indicated points, and shown with a calibrated voltage scale.

TYPE 1217-A UNIT PULSER

to maintain the grid of V-3 below the cutoff level through voltage divider R-28, R-35.) When the positive driving pulse from the blocking oscillator is applied to the grid of V-3, this tube begins to conduct, its plate voltage decreases, and the full decrease in plate voltage is applied (through the timing capacitor appropriate to the pulse duration to be produced) to the grid of V-2. V-2 is now in cutoff and V-3 in conduction. The positive voltage at the plate of V-2 is applied to the grid of V-3 through the grid divider circuit to keep V-3 on. This state will continue until the coupling capacitor between the plate of V-3 and grid of V-2 discharges sufficiently to permit V-2 to conduct again. When V-2 comes on, the feedback loop again operates, returning V-2 to conduction and V-3 to cutoff, to await the application of the next driving pulse. The time duration of the positive pulse depends, therefore, upon the component values in the grid coupling network of V-2 (R-2 and C-2 in the simplified diagram, Figure 4), the value of the voltage controlled by R-43, the cutoff value for V-2, and the plate swing of V-3. If we write down the equation connecting these variables, we find, for the pulse time⁵.

$$\text{Eq. 4 } T_p = R_2 C_2 \log \epsilon \frac{E_f + E_{p2}}{E_f + E_{co2}}$$

where E_f is the voltage set by R-43, E_{p2} is the plate swing of V-3 and E_{co2} is the value of cutoff voltage for V-2. E_f is made variable over a sufficient range to provide an 11:1 variation in T_p . The RC time constant is changed in decade multiples by the range switch to provide the multiples of pulse duration.

The charge lost by the grid coupling capacitor is replaced by grid current when the pulse portion of the cycle terminates. In order to speed the recharging of this capacitor, a diode, V-4B, is connected to a source of positive voltage approximating the cathode voltage of the monostable multivibrator.

3.4 LIMITER AND AMPLITUDE CONTROL CIRCUIT

The plate swing of V₂ of the monostable circuit (see Figure 8) is of the order of 100 volts. The d-c level of the pulse is shifted by a compensated voltage divider consisting of R-31, C-7, and R-30 to cause its base voltage to be slightly negative. When the pulse is produced, the voltage at the output terminals of the divider would normally rise to about +30 volts. Both the positive and negative excursions of voltage of the voltage divider are sufficient to cause the associated crystal diode limiters, D-2, D-3, to conduct. The negative limiter (D-3) is connected

5. Chance, B. et. al., Waveforms, Radiation Laboratory Series, Vol.19, p. 166.

GENERAL RADIO COMPANY

to a fixed source of -3.0 volts and limits the base of the pulse to that level, thus providing bias for the output tube. The voltage level corresponding to the "top" of the pulse is set by a second crystal limiter (D-2) connected to a variable voltage source of low impedance. This voltage source has the form of a series-tube cathode follower with grid potential derived from a regulated, high-impedance source of variable voltage.

There is some variation of the plate and bias supply voltages with both repetition frequency and pulse duration; therefore, both the maximum and minimum levels of the amplitude control voltage at the grid of the cathode follower must be regulated with respect to ground. The positive extreme of the amplitude control voltage is set by a neon glow tube, V-7, while the voltage for the minimum amplitude point is fixed by a thyrite element.

3.5 OUTPUT CIRCUIT AND ATTENUATOR

The pulse at the limiter junction is fed directly to the grid of the output stage. Both sections of a type 12AT7 tube are used in parallel as a cathode follower to provide an output impedance of about 200 ohms for the positive pulse when the shorting strap is in position on the negative pulse output terminals. If the external shorting strap is removed from the negative pulse output terminals and the negative pulse output is used, the output impedance of the stage is approximately 1800 ohms. Without this shorting strap, the equal plate and cathode resistors of this stage permit it to operate as a phase-splitter producing equal negative and positive going pulses. With the shorting strap connecting the cathode of the output stage to ground, the resulting amplifier has an output impedance of 1200 ohms and an open-circuit voltage of 60 volts. In order to minimize the effect of power-supply hum on the negative pulse, the plate supply wiring is made available to be used as the instrument ground for negative pulses. This is accomplished by connecting the ground terminal (J-6) of the negative-pulse binding post pair to B+ through C-25. If a particular application demands even lower noise on the negative pulse, a regulated plate supply should be used with the pulser to reduce hum.

In general, in order to increase the signal-to-noise ratio from the pulser, it is always better to use an external attenuator appropriate to the pulse being generated rather than the internal amplitude control since this control is prone to attenuate the pulse but not to attenuate small high-frequency spikes, hum, etc., by the same ratio. Toward this end, a simple 10:1 attenuator is included with the Type 1217-A Unit Pulser. When this unit is used to attenuate the positive pulse, a maximum pulse amplitude of 2.0 to 2.5 volts is available behind a stable impedance of 200 ohms. For particular applications, the user may make up his own attenuators using resistor values appropriate to desired voltage and required impedance.

TYPE 1217-A UNIT PULSER

SECTION 4.0 SERVICE AND MAINTENANCE NOTES

4.1 FOREWORD

The information contained in this section should enable the user to locate and correct any difficulties resulting from the normal use of the instrument.

A chart showing location of tubes will be found in the back of the dust cover.

Major service problems should be referred to the Service Department which will cooperate as far as possible by furnishing information and instructions, as well as by providing replacement parts when they may be needed. If the instrument is more than a year old, a reasonable charge may be expected for replacement parts or for reconditioning and recalibration.

Detailed reports to the Service Department should give instrument type number and operating conditions.

4.2 GENERAL

If the pulser becomes inoperative, a few simple checks should be made before the cover is removed.

4.21 Check the power line for proper voltage and frequency.

4.22 Check line cord, fuses, and voltage from power supply. (B+ demands are 300 v, 55 ma.)

4.23 If the power supply is functioning, check for presence of the synchronizing pulse at the SYNCHRONIZING terminal pair.

a. If both this pulse and an output pulse (with defects) are present, refer to Section 4.3.

b. If the synchronizing pulse is present but there is no output pulse, refer to Sections 4.4 and 4.5.

c. If both synchronizing pulse and output pulse are absent, refer to Section 4.6.

4.3 DEFECTS IN THE SHAPE OF THE PULSE

4.31 Large overshoot on pulse.

a. OVERSHOOT control misadjusted.

b. Load resistance too small for positive pulse output circuit (defect in this case will occur only above a given setting of the amplitude control).

GENERAL RADIO COMPANY

4.32 Pulse "ramp-off" (amplitude decreases gradually with time).

- a. For negative pulses of long duration, load impedance too small causing discharge of C-19 and C-25. This may be remedied, if necessary, by shunting C-25 with a larger blocking capacitor.
- b. Abrupt ramp-off or rise in base line beyond the 5 microseconds point on DURATION control for all time multiplier positions. Check V-2.

4.33 Excessive hum on negative pulse.

Excessive hum on negative pulse usually is caused by excessive hum from the power supply and power supply filter components should be checked.

4.34 Pulse amplitude low or not adjustable.

- a. Check D-2 and D-3 crystal diodes. (Forward Resistance = 100 ohms or less, Back Resistance = 500 k or more.)
- b. Check V-5.
- c. Check amplitude control voltage at pin 2 of V-5, minimum approximately -10 v, maximum approximately +25 v.
- d. Check V-2. See plate waveform, Figure 8.

4.35 Pulses present but not synchronized with oscillator. (Multivibrator free-running: This defect will ordinarily occur with the longer pulse duration settings on the MICROSECONDS dial). Replace V-2.

4.36 Jitter on trailing edge of 1 to 2 μ s pulse.

Decrease setting of C-8.

4.4 NO OUTPUT PULSE - SYNCHRONIZING PULSE PRESENT

With amplitude control fully clockwise, measure output voltage of POSITIVE pulse terminal with a voltmeter.

- a. If the voltage is 25, check V₂ (6AH6) and its associated components and voltages. See Figure 9.
- b. If the voltage is approximately 1 volt, then V₂ is conducting, so:
 - (1) Check V-3 and its components.
 - (2) Check for defective V-5.
 - (3) Check with oscilloscope (input capacitance 15 μ f or less) for 20-volt positive trigger pulse at pins 1 and 7 of V-4A (Figure 8).
 - (4) If check (3) reveals no trigger, check D-1 and delay network L-1, C-15, and C-21.
- c. If output voltage is zero or in excess +25 v, check V-6 and its components.

TYPE 1217-A UNIT PULSER

4.5 SYNCHRONIZING PULSE PRESENT - OUTPUT PULSE FAILS FOR SHORT PULSE DURATION SETTINGS ON THE MICROSECONDS SCALE.

This defect is caused by a weakening or low emission of the oscillator tube, V-1.

- a. Check for low line voltage.
- b. Increase setting of C-8, or
- c. Replace V-1.

4.6 NO OUTPUT PULSE WITH NO SYNCHRONIZING PULSE

4.61 All positions of the PULSES PER SECOND switch. This situation denotes a defective oscillator.

- a. Check V-1.
- b. Check T-1 windings for continuity.
- c. Check R-18 (1 k) and R-19 (100 ohms).
- d. Check resistance from pin 6 - T-1 to ground with V-1 removed from socket. Resistance for any switch position should be determined by resistor for that range (e.g., 1-kc position R-7 = 200 k). Complete failure of the oscillator would only be occasioned by a short or open circuit for all switch positions.

4.62 One or particular position of the PULSES PER SECOND switch fails.

- a. Check resistance from pin 6 to ground with the TRIGGER on INTERNAL operation at defective position, as in 4.61-d.
- b. If a consecutive group of frequency settings fail, check the capacitor appropriate to that group of frequencies:
 - 50 to 100-kc failure, check C-1
 - 1 to 20-kc failure, check C-23
 - 30 c - 1-kc failure, check C-2
 - 30 or 60 cps failure, check C-3 or C-4.

A shorted grid capacitor or switch position will cause excessive current in V-1 and will damage either or both V-1 and R-18.

4.7 ERRORS IN OSCILLATOR FREQUENCY OR LOCKING DEFECTS

4.71 Introduction: Oscillator frequency to some extent is dependent on V-1. In general, the frequency will rise slightly as V-1 ages. Tube replacement may shift the frequency centers by as much as 10%. If a particular frequency must be held more closely than $\pm(10$ to $15)\%$, it is recommended that either the appropriate timing resistor (R-1 through R-10) be modified to go with the oscillator tube, or that the oscillator be locked to an external source of adequate accuracy.

4.72 Frequency errors on one PULSES PER SECOND switch position.

GENERAL RADIO COMPANY

- a. Free-running frequency (100 cycles to 100 kc) - check appropriate resistor (R-1 through R-10), or capacitor if a group of frequencies are in error.
- b. Frequencies locked to power line.
 - (1) Check setting of R-58 to establish optimum lock for both 30 and 60 cps.
 - (2) Check components C-2, C-3, C-4, or R-11 and R-12.

4.73 Failure to lock properly with an external signal.

- a. Refer to Figure 5 to check locking conditions.
- b. Insufficient driving voltage or high-source impedance. (In order to drive the Type 1217-A Unit Pulser to the highest repetition rates at least 25 volts of signal behind 500 ohms must be available.)
- c. Oscillator inoperative for any input signal voltage.
 - (1) R-16 or Thyrite (R-51) open.
 - (2) C-6 open.
 - (3) Defective S-2.
- d. Oscillator free-running for all PULSES PER SECOND switch positions with TRIGGER SWITCH in EXTERNAL position. (Normally, the oscillator will run only on 30, 60 cps, and 100 kc positions.)
 - (1) R-17 open or increased in value.
 - (2) Open wire (yellow-green) in cable from S-2 to S-1.
- e. Oscillator free-running on some switch positions other than 30, 60 cps or 100 kc positions. This defect may occur when V-1 is replaced. The value of R-16 should be increased by substitution until oscillation stops - or a different 6AN5 may be chosen.

4.8 ROUTINE MAINTENANCE

In order to obtain peak performance at minimum cost, some tubes in this instrument are operated close to their maximum design limits. In order to insure peak performance, it is therefore recommended THAT V-2 (6AH6) AND V-3 (6AK5) BE CHECKED BY REPLACEMENT ABOUT EVERY SIX MONTHS OF NORMAL OPERATION, AND THAT V-2 BE REPLACED AS A MATTER OF ROUTINE ABOUT ONCE A YEAR. (The first sign of a weakening V-2 is difficulty in maintaining a flat base line at close to maximum pulse duration on the X100 position of PULSE DURATION MULTIPLIER at low line voltages - 105 volts.)

TYPE 1217-A UNIT PULSER

Figure 9. Vacuum-Tube Data.

Conditions: 1 μ sec pulse, 1 kc PRF, Amplitude Control at Maximum (115-volt line)

Voltmeter: 20,000 ohms/volt dc; 1000 ohms/volt ac

	#1	#2	#3	#4	#5	#6	#7	#8	#9
V-1 6AN5	-75v	0	0	6.3v ac	+230v	+230v	--	XX	XX
V-2 6AH6	+16v	+16v	0	6.3v ac	+70	+140	+16v	XX	XX
V-3 6AK5	+4v	+16v	0	6.3v ac	+225v	+140	+16v	XX	XX
V-4 6AL5	+4v	+16v	0	6.3v ac	+16v	--	0	XX	XX
V-5 12AT7	+150v	+23v*	+26v	6.3v ac	6.3v ac	+26v	-78v	-80v	0
V-6 12AT7	+220v	-6.5v	+0.4v	0	0	+220v	-6.5v	+0.4v	6.3v ac

*Measured with Vacuum-Tube Voltmeter.

Parts List

RESISTORS	TYPE
R-1 = 47 kilohms \pm 5%	REC-20BF
R-2 = 68 kilohms \pm 5%	REC-20BF
R-3 = 22 kilohms \pm 5%	REC-20BF
R-4 = 47 kilohms \pm 5%	REC-20BF
R-5 = 91 kilohms \pm 5%	REC-20BF
R-6 = 220 kilohms \pm 5%	REC-20BF
R-7 = 200 kilohms \pm 5%	REC-20BF
R-8 = 390 kilohms \pm 5%	REC-20BF
R-9 = 1.5 Megohms \pm 5%	REC-20BF
R-10 = 2.7 Megohms \pm 5%	REC-20BF
R-11 = 680 kilohms \pm 5%	REC-20BF
R-12 = 1.3 Megohms \pm 5%	REC-20BF
R-13 = 10 kilohms \pm 10%	REC-30BF
R-14 = 22 kilohms \pm 10%	REC-30BF
R-15 = 15 kilohms \pm 10%	REC-20BF
□ R-16 =	REC-20BF
R-17 = 39 kilohms \pm 5%	REC-20BF
R-18 = 1 kilohm \pm 10%	REC-30BF
R-19 = 100 Ohms \pm 5%	REC-20BF
R-20 = 47 kilohms \pm 5%	REC-20BF
R-21 = 1.5 kilohms \pm 5%	REC-20BF
R-22 = 68 kilohms \pm 5%	REC-20BF
R-23 = 270 kilohms \pm 5%	REC-20BF
R-24 = 8.2 kilohms \pm 5%	REC-20BF
R-25 = 260 kilohms \pm 1%	REF-70
R-26 = 100 Ohms \pm 5%	REC-20BF
R-27 = 5.6 kilohms \pm 5%	1391-40
R-28 = 47 kilohms \pm 5%	REC-30BF
R-29 = 1 Megohm \pm 5%	REC-20BF
R-30 = 82 kilohms \pm 5%	REC-20BF
R-31 = 110 kilohms \pm 5%	REC-20BF
R-32 = 7.5 kilohms \pm 5%	REC-30BF
R-33 = 5.1 kilohms \pm 5%	REC-41BF

□ VALUE TO BE SELECTED AND ADDED IN LAB.

GENERAL RADIO COMPANY

Parts List (Cont)

R-34	=	430 Ohms	± 5%	REC-20BF
R-35	=	3 kilohms	± 5%	REC-20BF
R-36	=	2.4 Megohms	± 5%	REC-20BF
R-37	=	1.8 kilohms	± 5%	REC-41BF
R-38	=	1.8 kilohms	± 5%	REC-41BF
R-39	=	68 kilohms	±10%	REC-20BF
R-40	=	1 Megohm	±10%	POSC-7
R-41	=	5.6 Megohms	±10%	REC-20BF
R-42	=	180 Ohms	±10%	REC-20BF
R-43	=	52 kilohms	± 5%	301-489
R-44	=	750 Ohms	± 5%	REC-20BF
R-45	=	2 kilohms	± 5%	REPO-22
R-46	=	12 kilohms	±10%	REC-30BF
R-47	=	3.3 Megohms	± 5%	REC-20BF
R-48	=			
R-49	=	390 Ohms	±10%	REC-20BF
R-50	=	33 kilohms	± 5%	REC-30BF
R-51	=	(Thyrite)		REU-8
R-52	=	(Thyrite)		REU-8
R-53	=	680 Ohms	±10%	REC-20BF
R-54	=	5.6 Megohms	±10%	REC-20BF
R-55	=	82 Ohms	±10%	REC-20BF
R-56	=	110 kilohms	± 5%	REC-20BF
R-57	=	56 kilohms	±10%	REC-20BF
R-58	=	50 kilohms	±10%	POSC-11
R-59	=	18 kilohms	± 5%	REC-20BF
R-60	=	1 kilohm	± 5%	REC-20BF
R-61	=	5.6 kilohms	±10%	REC-20BF
R-62	=			
*R-63	=	100 Ohms	± 5%	REC-20BF
CONDENSERS:				
C-1	=	100 μ f	± 1%	COM-20E
C-2	=	.00185 μ f	± 2%	COM-30E
C-3	=	0.01 μ f	± 1%	COM-35E
C-4	=	0.01 μ f	± 1%	COM-35E
C-5	=	0.1 μ f	±10%	COW-25
C-6	=	0.22 μ f	±10%	COW-16
C-7	=	3-25 μ f		COA-1L
C-8	=	7-45 μ f		COT-12
C-9	=	4.7 μ f	±10%	COC-1
C-10	=	400 μ f	± 5%	COM-20B
C-11	=	0.22 μ f	±10%	COW-17
C-12	=	5-20 μ f		COT-18
C-13	=	90 μ t	± 2%	COM-20E
C-14	=	0.01 μ f	± 1%	COM-35E
C-15	=	22 μ f	±10%	COC-21
C-16	=	0.1 μ f	±10%	COW-25
C-17	=	0.01 μ f	±10%	COW-25
C-18	=	100 μ f	150 W.V.	COE-45
C-19	=	0.47 μ f	±10%	COW-25

*TO BE ADDED IN LAB. IF REQUIRED

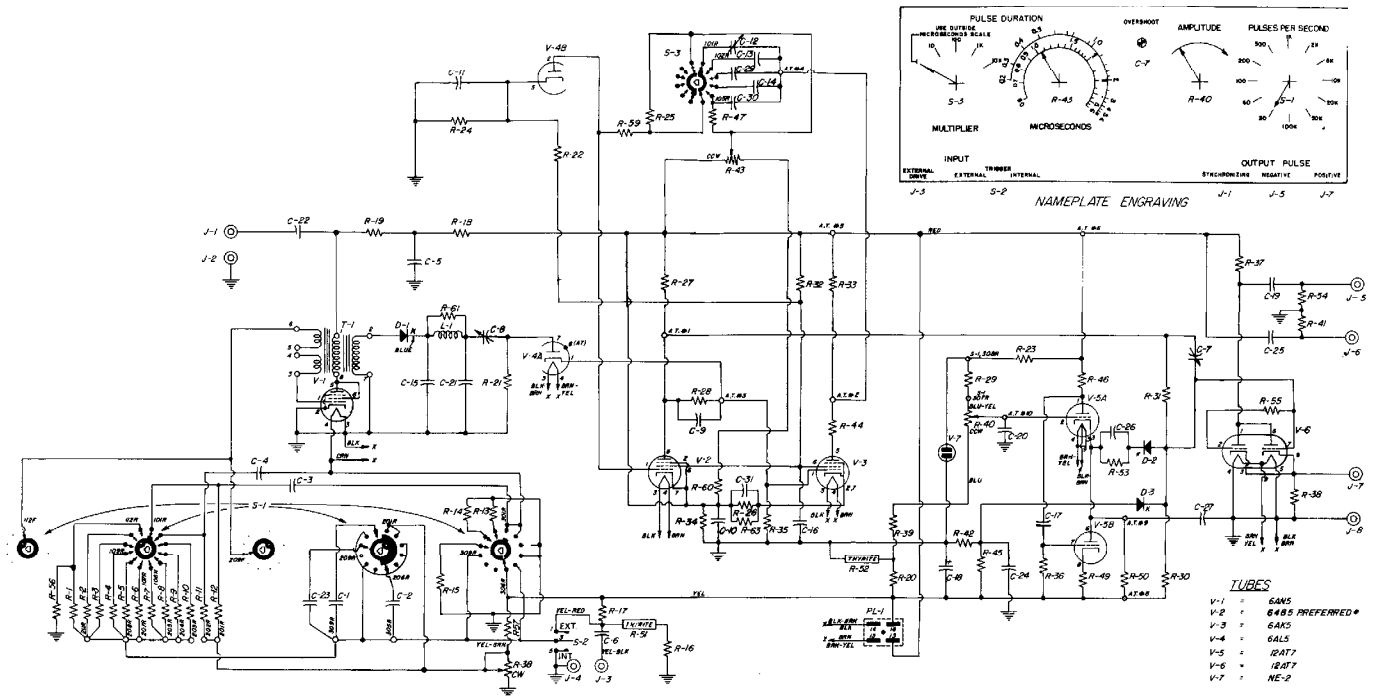

Figure 10. Wiring diagram for the Type 1217-A Unit Pulser.

Parts List (Cont)

C-20	=	0.001	μf	±10%	COH-20B	MISCELLANEOUS	J-8	=	Binding Post	BP-10, 11/16
C-21	=	22	μμf	±10%	CC-C-21	D-1	=	Plug	CDHP-476-4	
C-22	=	0.001	μf	±10%	COH-20B	D-2	=	Choke 55μh	ZCHA-42 ± 5%	
C-23	=	0.001	μf	± 1%	COH-30E	D-3	=	Crystal Detector	INI18	
C-24	=	0.1	μf	±10%	COM-17	J-1	=	Binding Post	BP-5	
C-25	=	0.47	μf	±10%	COM-25	J-2	=	Binding Post	BP-10, 11/16	
C-26	=	0.001	μf	±10%	COH-20B	J-3	=	Binding Post	BP-5	
C-27	=	0.1	μf	±10%	COM-17	J-4	=	Binding Post	BP-10, 11/16	
C-28	=					J-5	=	Binding Post	BP-5B	
C-29	=	.001	μf	± 1%	COM-30E	J-6	=	Binding Post	BP-5B	
C-30	=	0.1	μf	± 5%	COM-25	J-7	=	Binding Post	BP-5R	
C-31	=	.001	μf	±10%	COM-20B					

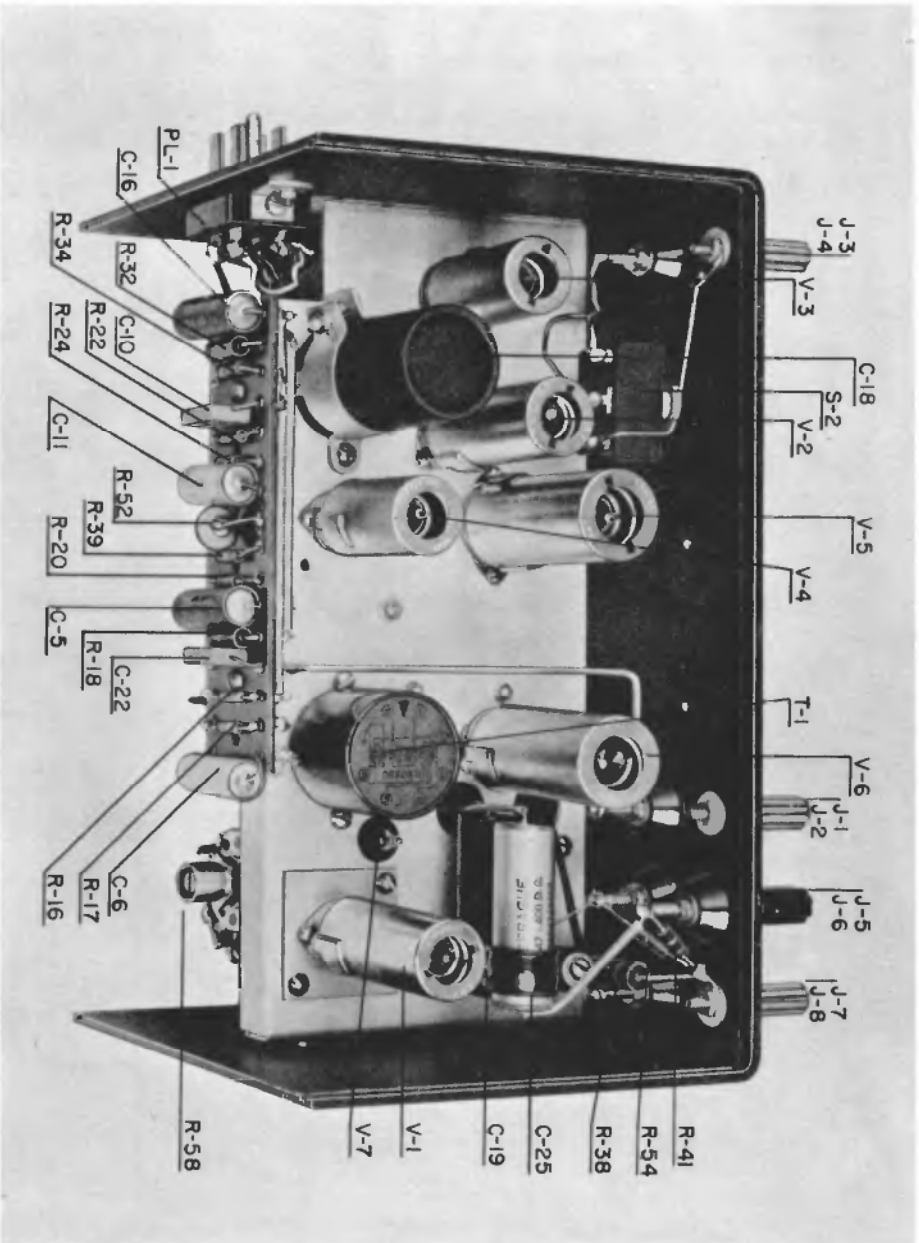

Figure 11. Bottom rear interior view of Type 1217-A Unit Pulser.

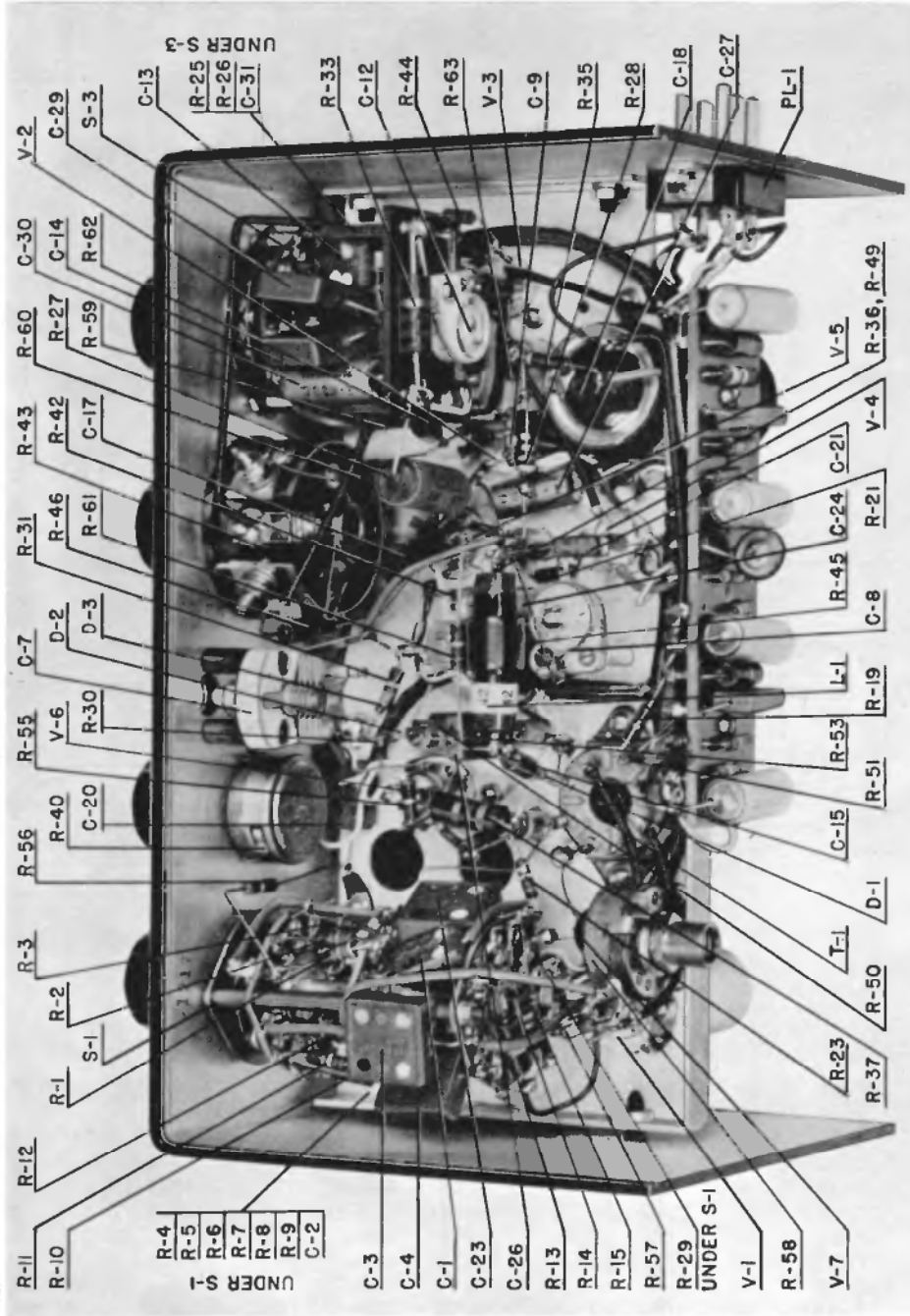

Figure 12. Top rear interior view of Type 1217-A Unit Pulser.